

Exam

Name _____

MULTIPLE CHOICE. Choose the one alternative that best completes the statement or answers the question.

Solve the inequality.

1) $-11 - 10x - 11 \geq -11x - 12$ 1) _____
A) $x > -10$ B) $x < -10$ C) $x \leq 10$ D) $x \geq 10$

2) $-15x - 9 \leq -3(4x - 2)$ 2) _____
A) $x \geq -5$ B) $x < -5$ C) $x > -5$ D) $x \leq -5$

Solve the inequality and give the solution in interval notation.

3) $-30r + 15 \leq -5(5r + 1)$ 3) _____
A) $(4, \infty)$ B) $(-\infty, 4)$ C) $(-\infty, 4]$ D) $[4, \infty)$

4) $7x + 5 \geq 4$ and $9x - 4 < 9$ 4) _____
A) $[-\frac{1}{7}, \frac{5}{9})$ B) $[-\frac{1}{7}, \frac{13}{9})$ C) $(-\frac{1}{7}, \frac{5}{9}]$ D) $(-\frac{1}{7}, \frac{13}{9}]$

Solve the inequality.

5) $-4 < \frac{-3(4 - x)}{5} < \frac{2}{9}$ 5) _____
A) $-\frac{8}{3} < x < \frac{22}{3}$ B) $-\frac{8}{3} < x < \frac{118}{27}$ C) $-\frac{118}{27} < x < \frac{8}{3}$ D) $-\frac{22}{3} < x < \frac{8}{3}$

Solve the problem.

6) The water acidity in a pool is considered normal when the average pH reading of three daily measurements is greater than 7.2 and less than 7.8. If the first two pH reading are 7.25 and 7.85, find the range of pH values for the third reading that will result in the acidity level being normal. 6) _____
A) $6.5 < x < 8.3$ B) $7.7 < x < 9.5$ C) $7.2 < x < 7.8$ D) $7.1 < x < 8.9$

Solve the inequality and give the solution in interval notation.

7) $9x - 8 > 28$ or $-x + 4 \geq -8$ 7) _____
A) $[4, 12)$ B) $(4, 12]$ C) $(4, \infty)$ D) $(-\infty, \infty)$

Find the solution set for the equation.

8) $|7m + 2| = 6$ 8) _____
A) $\{2, -4\}$ B) $\{-\frac{4}{7}, \frac{8}{7}\}$ C) $\{\frac{4}{7}, -\frac{8}{7}\}$ D) \emptyset

9) $3 + \left| \frac{2 - x}{2} \right| = 5$ 9) _____
A) $\{-2, 6\}$ B) $\{-6, 6\}$ C) $\{-2, 2\}$ D) $\{-6, 2\}$

Find the solution set for the inequality.

10) $|5m + 3| + 4 \geq 9$

A) $\{m \mid -\frac{8}{5} \leq m \leq \frac{2}{5}\}$

B) $\{m \mid m \leq -\frac{8}{5} \text{ or } m \geq \frac{2}{5}\}$

C) $\{m \mid m \leq -\frac{2}{5} \text{ or } m \geq \frac{8}{5}\}$

D) $\{m \mid -\frac{2}{5} \leq m \leq \frac{8}{5}\}$

10) _____

11) $|2m + 3| + 5 \leq 12$

A) $\{m \mid m \leq -2 \text{ or } m \geq 5\}$

B) $\{m \mid m \leq -5 \text{ or } m \geq 2\}$

C) $\{m \mid -5 \leq m \leq 2\}$

D) $\{m \mid -2 \leq m \leq 5\}$

11) _____

Determine whether the given ordered pair is a solution to the given equation.

12) $(6, -5); 3x^2 + 8xy - 2y^2 = -237$

A) yes

B) no

12) _____

Determine if the relation illustrated is a function. Give the domain and range of the function or relation.

13) $\{(11, -4), (-5, -3), (-5, 0), (4, 3), (20, 5)\}$

A) not a function

B) function

domain: $\{-4, -3, 0, 3, 5\}$

domain: $\{11, 4, -5, 20\}$

range: $\{11, 4, -5, 20\}$

range: $\{-4, -3, 0, 3, 5\}$

C) function

D) not a function

domain: $\{-4, -3, 0, 3, 5\}$

domain: $\{11, 4, -5, 20\}$

range: $\{11, 4, -5, 20\}$

range: $\{-4, -3, 0, 3, 5\}$

13) _____

Determine whether the graph illustrated represents a function. Give the domain and range of the relation or function.

14)

14) _____

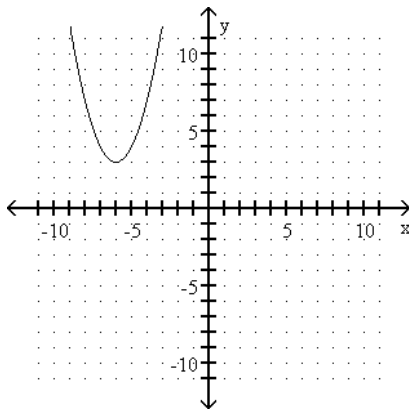

A) function

B) function

domain: \mathcal{R}

domain: $\{x \mid x \geq 3\}$

range: $\{y \mid y \geq 3\}$

range: \mathcal{R}

C) not a function

D) not a function

domain: $\{x \mid x \geq 3\}$

domain: \mathcal{R}

range: \mathcal{R}

range: $\{y \mid y \geq 3\}$

Evaluate the function for the indicated value.

15) $f(x) = \sqrt{x + 12}$; find $f(-3)$

A) 3

B) -36

C) -3

D) 1.73

15) _____

16) $f(x) = \frac{x^2 + 7}{x^3 + 7x}$; find $f(-4)$

16) _____

A) $-\frac{1}{4}$

B) $-\frac{4}{23}$

C) $-\frac{23}{64}$

D) $-\frac{23}{57}$

Solve the problem.

17) The population of fruit flies, p , after n days from the first mating of ten flies is given by the function

17) _____

$p(n) = 0.07x^2 + 0.13x$. Find the population of fruit flies after

i) 20 days

ii) 30 days

A) i) 30

B) i) 16

C) i) 30

D) i) 16

ii) 66

ii) 119

ii) 119

ii) 66

Write the equation in standard form.

18) $y + 5 = -\frac{2}{5}(x - 9)$

18) _____

A) $2x + 5y = 43$

B) $2x + 5y = -7$

C) $2x - 5y = -7$

D) $2x - 5y = 43$

Find the slope of the line through the given points. If the slope is undefined, so state.

19) $(-7, -9)$ and $(-7, 3)$

19) _____

A) $\frac{3}{7}$

B) $\frac{6}{7}$

C) 0

D) undefined

Solve the inequality and give the solution in interval notation.

20) $-15 \leq -2x - 5 < -13$

20) _____

A) $(-5, -4)$

B) $[4, 5)$

C) $(4, 5]$

D) $[-5, -4)$

Solve for k if the line through the two given points is to have the given slope.

21) $(2, 4)$ and $(4, k)$, $m = \frac{3}{2}$

21) _____

A) $k = -7$

B) $k = \frac{16}{3}$

C) $k = 7$

D) $k = -\frac{16}{3}$

Find the slope of the line. If the slope is undefined, so state.

22)

22) _____

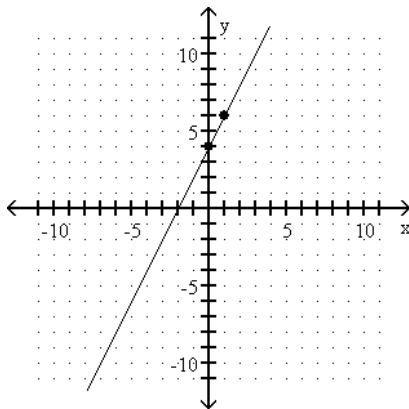

A) $-\frac{1}{2}$

B) $\frac{1}{2}$

C) 2

D) -2

Write the equation of the line.

23)

23) _____

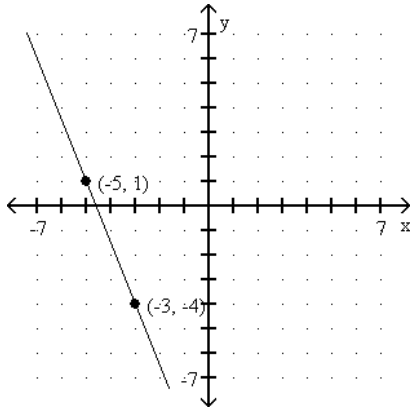

A) $y = -\frac{5}{2}x + \frac{11}{2}$

B) $y = -\frac{5}{2}x - \frac{17}{2}$

C) $y = -\frac{5}{2}x - \frac{23}{2}$

D) $y = -\frac{2}{5}x - \frac{10}{23}$

Write the equation in slope-intercept form.

24) $-3x + 5y = 15$

24) _____

A) $y = -\frac{3}{5}x + 3$

B) $y = -\frac{5}{3}x - 5$

C) $y = \frac{3}{5}x + 3$

D) $y = \frac{5}{3}x - 5$

Solve the problem.

25) If one point on a graph is (4, 4) and the slope of the line is $-\frac{4}{9}$, write the equation of the line in slope-intercept form.

25) _____

A) $y = -\frac{4}{9}x - \frac{52}{9}$

B) $y = -\frac{4}{9}x + \frac{52}{9}$

C) $y = -\frac{9}{4}x - 13$

D) $y = \frac{4}{9}x - \frac{52}{9}$

Determine the slope and the y-intercept of the graph of the equation.

26) $8x - 2y = 16$

26) _____

A) $m = -4; (0, 8)$

B) $m = \frac{1}{4}; (0, 2)$

C) $m = 4; (0, -8)$

D) $m = 8; (0, 16)$

Given the graph of an equation of the form $y = mx + b$, what can be said about m and b?

27)

27) _____

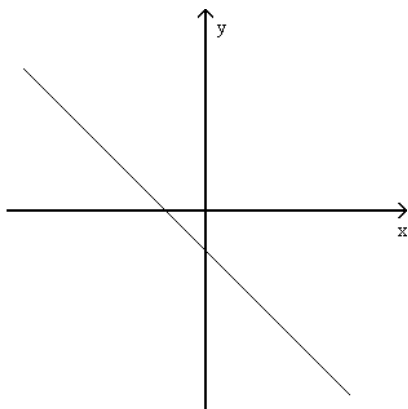

A) $m > 0, b < 0$

B) $m > 0, b > 0$

C) $m < 0, b > 0$

D) $m < 0, b < 0$

Two points on L_1 and two points on L_2 are given. Determine whether L_1 is parallel to L_2 , L_1 is perpendicular to L_2 , or neither.

- 28) $L_1: (2, 2), (3, 0); L_2: (3, -2), (5, -1)$ 28) _____
A) parallel B) perpendicular C) neither

Determine whether the two given lines are parallel, perpendicular, or neither.

- 29) $3x = 5y + 20$ 29) _____
 $y = \frac{3}{5}x - 1$
A) parallel B) perpendicular C) neither

Find the equation of a line with the properties given. Write the equation in the form indicated.

- 30) Passing through $(3, 5)$ and perpendicular to the line whose equation is $-7x + y = 6$; slope-intercept form 30) _____
A) $y = -\frac{1}{7}x - \frac{38}{7}$ B) $y = -7x - 38$ C) $y = -\frac{1}{7}x + \frac{38}{7}$ D) $y = \frac{1}{7}x - \frac{38}{7}$

Find the requested value.

- 31) $f(x) = 4x^2 + 3x - 2, g(x) = 2x - 7$ 31) _____
Find $f(2) + g(2)$.
A) 14 B) 21 C) -15 D) 17
- 32) $f(x) = x - 4, g(x) = -2x^2 + 13x - 5$ 32) _____
Find $(f \cdot g)(2)$.
A) -26 B) -50 C) 78 D) -78

Graph the inequality.

33) $2x + 3y \leq 6$

33) _____

A)

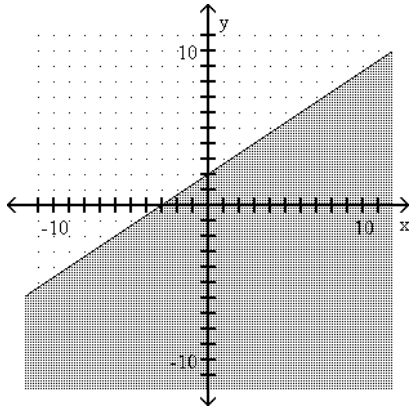

B)

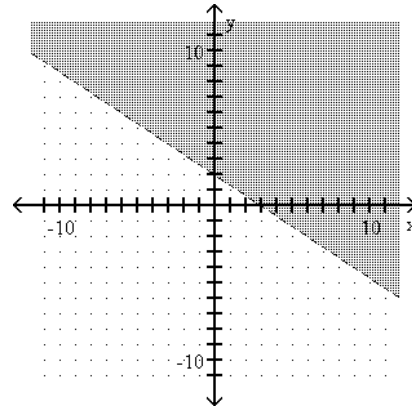

C)

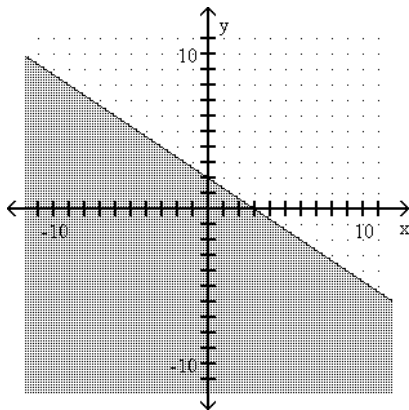

D)

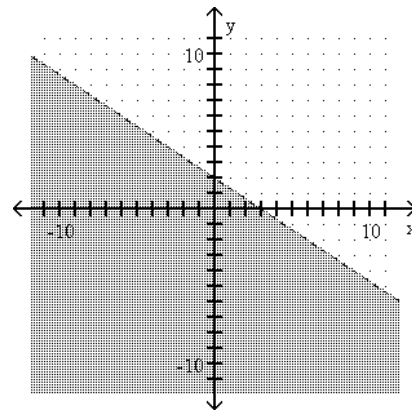

Find the solution to the system of equations by substitution.

34) $x + 4y = 7$

$-3x - 12y = -21$

A) (0, 0)

C) infinite number of solutions

B) (7, 0)

D) no solution

34) _____

Solve the system of equations using the addition method.

35) $3x + \frac{1}{2}y = 0$

$2x + \frac{5}{2}y = 13$

A) (1, 5)

B) (0, 5)

C) (-1, 6)

D) no solution

35) _____

36) $3x + 5y + z = 1$

$5x - 2y - z = 33$

$5x + y + 3z = 11$

A) (5, -2, -4)

B) (-2, 5, -4)

C) (-4, -2, 5)

D) (5, -4, -2)

36) _____

Solve the problem.

- 37) Mr. Alexander earns a weekly salary plus a commission from his position as a salesman. One week his total compensation on sales of \$4000 was \$640. The next week his total compensation on sales of \$3000 was \$600. Find Mr. Alexander's weekly salary and his commission rate. 37) _____

- A) weekly salary: \$480
commission rate: 4%
B) weekly salary: \$400
commission rate: 4.8%
C) weekly salary: \$470
commission rate: 5%
D) weekly salary: \$490
commission rate: 3%

- 38) A twin-engined aircraft can fly 612 miles from city A to city B in 3 hours with the wind and make the return trip in 6 hours against the wind. What is the speed of the wind? 38) _____

- A) 85 mph B) 34 mph C) 68 mph D) 51 mph

Find the domain of.

- 39) $\frac{x - 5}{x^2 - 81}$ 39) _____

- A) 81 B) $\frac{5}{81}$ C) 9, -9 D) 9

- 40) $\frac{x^2 - 25}{2x^2 - 5x - 7}$ 40) _____

- A) -5, -1, $\frac{7}{2}$, 5 B) $-\frac{7}{2}$, 1 C) -5, 5 D) -1, $\frac{7}{2}$

Solve the equation and check your solution.

- 41) $\frac{x}{3} - \frac{x}{8} = 4$ 41) _____

- A) 24 B) 12 C) $\frac{96}{5}$ D) 32

- 42) $\frac{27}{x} = 7 - \frac{1}{x}$ 42) _____

- A) $\frac{27}{7}$ B) $\frac{7}{26}$ C) 4 D) 3

Write the expression in exponential form. Assume that all variables represent positive real numbers.

- 43) $\sqrt[9]{2x + 5y}$ 43) _____

- A) $(2x + 5y)^{1/9}$ B) $(2x + 5y)^3$ C) $(2x + 5y)^{1/3}$ D) $(\frac{2}{3}x + \frac{5}{3}y)^{1/3}$

Write the expression in radical form. Assume that all variables represent positive real numbers.

- 44) $(6x^2y^3)^{5/3}$ 44) _____

- A) $\left(\sqrt[5]{\frac{6}{5}x^2y^3}\right)^3$ B) $\left(\sqrt[5]{6x^2y^3}\right)^3$ C) $\left(\sqrt[3]{6x^2y^3}\right)^5$ D) $\left(\sqrt[3]{2x^2y^3}\right)^5$

Simplify the radical expression. Write the answer in radical form when appropriate.

45) $(\sqrt[4]{x^3yz^5})^{40}$ 45) _____
 A) $x^{30}yz^{50}$ B) $x^3y^{10}z^5$ C) $x^{30}y^{10}z^5$ D) $x^3y^{10}z^{50}$

Simplify.

46) $\sqrt{81} + \sqrt{605} + \sqrt{49} + \sqrt{45}$ 46) _____
 A) $14\sqrt{5} + 16$ B) $130\sqrt{5} + 16$
 C) $\sqrt{605} + \sqrt{45} + 16$ D) $14\sqrt{5} + \sqrt{81} + \sqrt{49}$

47) $\sqrt{3} - 6\sqrt{108} + 3\sqrt{300}$ 47) _____
 A) $-3\sqrt{3}$ B) $-5\sqrt{3}$ C) $-5\sqrt{411}$ D) $-3\sqrt{411}$

48) $x^2\sqrt[3]{64x^4y^2} - x^3\sqrt[3]{xy^2} + 9x\sqrt[3]{x^7y^2}$ 48) _____
 A) $12x^3\sqrt[3]{xy^2}$ B) $-6x^3\sqrt[3]{xy^2}$ C) $13x^3\sqrt[3]{xy^2}$ D) $12x^3\sqrt[3]{y^2}$

49) $\sqrt{5}(\sqrt{45} + \sqrt{15})$ 49) _____
 A) $225 + 5\sqrt{3}$ B) $15 + 5\sqrt{3}$ C) $15 + 25\sqrt{3}$ D) 30

50) $\sqrt{72}\sqrt{50}$ 50) _____
 A) 30 B) 50 C) $30\sqrt{2}$ D) 60

51) $(\sqrt{10} + \sqrt{2})(\sqrt{10} - \sqrt{2})$ 51) _____
 A) 8 B) $10 - 2\sqrt{10}$ C) 12 D) $10 - 2\sqrt{2}$

52) $\sqrt[3]{2xy^2}\sqrt[3]{4x^{10}y^{12}}$ 52) _____
 A) $2x^4y^5\sqrt[3]{xy}$ B) $4x^3y^4\sqrt[3]{x^2y^2}$ C) $2x^3y^4\sqrt[3]{xy}$ D) $2x^3y^4\sqrt[3]{x^2y^2}$

Simplify by rationalizing the denominator.

53) $\frac{6}{8 - \sqrt{5}}$ 53) _____
 A) $\frac{48 + 6\sqrt{5}}{-3}$ B) $\frac{6}{8} - \frac{6}{\sqrt{5}}$ C) $\frac{48 + 6\sqrt{5}}{59}$ D) $\frac{48 - 6\sqrt{5}}{59}$

54) $\frac{\sqrt{x} - 20}{\sqrt{x} + \sqrt{6}}$ 54) _____
 A) $\frac{x - 26\sqrt{x} + 20\sqrt{6}}{x - 6}$ B) $\frac{x - \sqrt{6x} - 20\sqrt{x} + 20\sqrt{6}}{x - 6}$
 C) $\frac{-20\sqrt{6}}{6}$ D) $\frac{\sqrt{6x} + 20\sqrt{x} - 20\sqrt{6}}{6}$

Solve and check your solution(s). If the equation has no real solution, so state.

55) $\sqrt[3]{3+7x} - \sqrt[3]{4-2x} = 0$

- A) -9 B) $\frac{1}{9}$ C) $-\frac{1}{9}$ D) 9

55) _____

Solve. You will have to square both sides of the equation twice to eliminate all radicals.

56) $\sqrt{2x+5} = 3 + \sqrt{x-2}$

- A) -2, 38 B) -38, -2 C) 2, 38 D) no real solution

56) _____

57) $\sqrt{x+6} + \sqrt{2-x} = 4$

- A) 0 B) 2, -2 C) -2 D) no real solution

57) _____

Add or subtract.

58) $(3 - 3i) + (2 - 7i) + (4 + 5i)$

- A) $1 - 15i$ B) $5 - 10i$ C) $9 - 5i$ D) $5 + 9i$

58) _____

Multiply. Write the result in the form $a + bi$.

59) $(3 + 8i)(8 + 7i)$

- A) $56i^2 + 85i + 24$ B) $80 + 43i$ C) $-32 + 85i$ D) $-32 - 85i$

59) _____

Divide.

60) $\frac{17 - 30i}{5 - 2i}$

- A) $5 - 4i$ B) $-4 + 5i$ C) $5 + 4i$ D) $-4 - 5i$

60) _____

Evaluate.

61) i^{38}

- A) i B) -1 C) 1 D) $-i$

61) _____

Use the square root property to solve the equation.

62) $7x^2 + 2 = 177$

- A) ± 6 B) ± 5 C) 88.5 D) 5

62) _____

63) $(4x + 3)^2 = 10$

- A) $\frac{3 \pm \sqrt{10}}{4}$ B) $-\frac{13}{4}, \frac{7}{4}$ C) $\frac{\sqrt{10} \pm 3}{4}$ D) $\frac{-3 \pm \sqrt{10}}{4}$

63) _____

64) $\left(x - \frac{1}{2}\right)^2 = \frac{9}{4}$

- A) 2, -1 B) 1, -2 C) 2, -4 D) 4, -2

64) _____

Solve the equation by completing the square.

65) $x^2 + 4x - 9 = 0$

- A) $2 + \sqrt{13}$ B) $-2 \pm 2\sqrt{13}$ C) $-2 \pm \sqrt{13}$ D) $-1 \pm \sqrt{13}$

65) _____

66) $5x^2 - 2x - 5 = 0$

A) $\frac{1 \pm \sqrt{26}}{5}$

B) $\frac{-1 \pm \sqrt{26}}{5}$

C) $-5, \frac{27}{5}$

D) $\frac{5 \pm \sqrt{26}}{25}$

66) _____

Solve the equation by the quadratic formula.

67) $\frac{x^2}{16} + x + \frac{21}{8} = 0$

A) $-8 \pm \sqrt{22}$

B) $-16 + \sqrt{42}$

C) $8 \pm \sqrt{42}$

D) $8 + \sqrt{22}$

67) _____

Write an equation that has the given solutions.

68) $-4, -3$

A) $x^2 - 7x + 12 = 0$

B) $x^2 + 7x + 12 = 0$

C) $x^2 + 12x - 7 = 0$

D) $x^2 - 12x - 7 = 0$

68) _____

Use the discriminant to determine whether the equation has two distinct real solutions, a single real solution, or no real solution.

69) $7x^2 = 2x - 5$

A) two real solutions

B) no real solution

C) one real solution

69) _____

70) $x^2 + 7x + 6 = 0$

A) no real solution

B) two real solutions

C) one real solution

70) _____

Solve the equation.

71) $(4x - 6)^2 - 4(4x - 6) - 5 = 0$

A) $-\frac{7}{4}, \frac{1}{4}$

B) $-\frac{5}{4}, -\frac{11}{4}$

C) $-\frac{1}{6}, \frac{7}{4}$

D) $\frac{11}{4}, \frac{5}{4}$

71) _____

72) $x^4 - 3x^2 - 54 = 0$

A) $-9, 6$

B) ± 3

C) $\pm 3, \pm i\sqrt{6}$

D) $3, i\sqrt{6}$

72) _____

73) $2x - 13\sqrt{x} - 70 = 0$

A) $\frac{49}{4}, 100$

B) 10

C) $\frac{7}{2}, 10$

D) 100

73) _____

74) $x^{2/3} - 2x^{1/3} - 3 = 0$

A) $-3, 1$

B) $-1, 27$

C) $-1, 3$

D) $-27, 1$

74) _____

75) $30x^{-2} + x^{-1} - 1 = 0$

A) $\frac{1}{6}, -\frac{1}{5}$

B) $-6, 5$

C) $-\frac{1}{6}, \frac{1}{5}$

D) $6, -5$

75) _____

Find the vertex and axis of symmetry of the graph of the function.

76) $f(x) = x^2 + 8x + 21$

A) vertex: $(-4, 5)$; $x = -4$ B) vertex: $(5, -4)$; $x = 5$ C) vertex: $(5, -16)$; $x = 5$ D) vertex: $(-5, 4)$; $x = -5$

76) _____

Determine whether the parabola opens upward or downward.

77) $y = -x^2 + 2x - 5$

A) upward

B) downward

77) _____

For the given functions f and g , find the indicated composition.

78) $f(x) = 3x + 13$, $g(x) = 5x - 1$

$(f \circ g)(x)$

A) $15x + 12$

B) $15x + 64$

C) $15x + 10$

D) $15x + 16$

78) _____

For the given functions f and g , find the indicated value.

79) $f(x) = x^2 + 6x$, $g(x) = x + 2$

$(g \circ f)(4)$

A) 44

B) 42

C) 72

D) 240

79) _____

Determine whether the given function is one-to-one. If it is one-to-one, find its inverse function.

80) $f(x) = x^3 + 6$

A) one-to-one function; $f^{-1}(x) = \sqrt[3]{x} - 6$

B) one-to-one function; $f^{-1}(x) = \sqrt[3]{x - 6}$

C) one-to-one function; $f^{-1}(x) = \sqrt[3]{x + 6}$

D) not a one-to-one function

80) _____

Graph the function.

81) $f(x) = 3^{-x}$

81) _____

A)

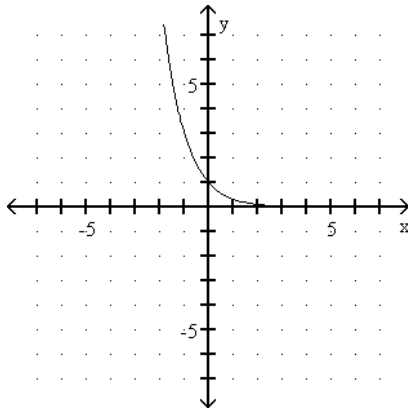

B)

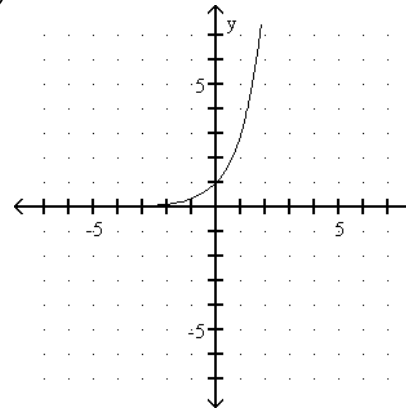

C)

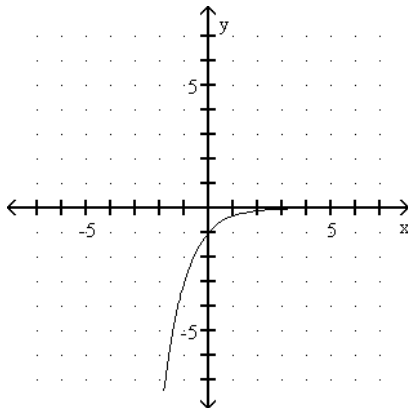

D)

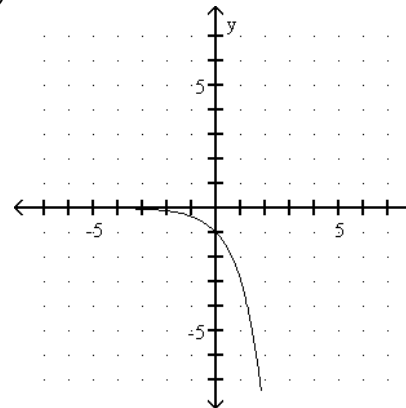

Write the equation in logarithmic form.

82) $343^{1/3} = 7$

A) $\log_7 \frac{1}{3} = 343$

B) $\log_3 343 = 7$

C) $\log_{343} \frac{1}{3} = 7$

D) $\log_{343} 7 = \frac{1}{3}$

82) _____

Write the equation in exponential form.

83) $\log_4 \left(\frac{1}{16} \right) = -2$

A) $2^4 = \frac{1}{16}$

B) $4^{16} = 2$

C) $4^{-2} = \frac{1}{16}$

D) $\left(\frac{1}{16} \right)^2 = 4$

83) _____

Find the unknown value.

84) $\log_9 \frac{1}{81} = y$

A) 2

B) -9

C) 9

D) -2

84) _____

85) $\log_3 x = 2$

A) 5

B) 9

C) 8

D) 6

85) _____

86) $\log_a 64 = 2$

A) 8

B) $-\frac{1}{8}$

C) -8

D) $\frac{1}{8}$

86) _____

Evaluate.

87) $\log_{10} \frac{1}{1000}$

A) $\frac{1}{1000}$

B) 30

C) 3

D) -3

87) _____

88) $\log_{10} \frac{1}{100}$

A) 2

B) 20

C) -2

D) $\frac{1}{100}$

88) _____

Graph the function.

89) $y = \log_5 x$

89) _____

A)

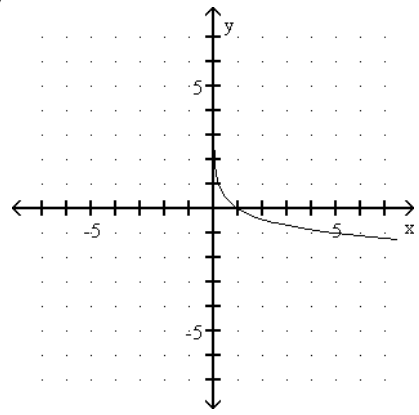

B)

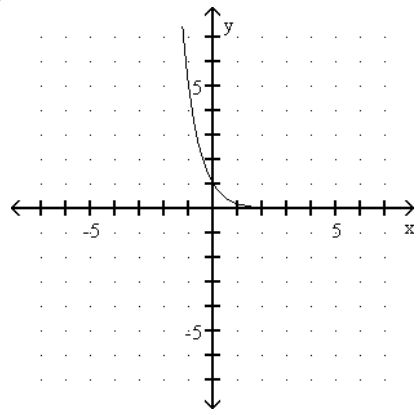

C)

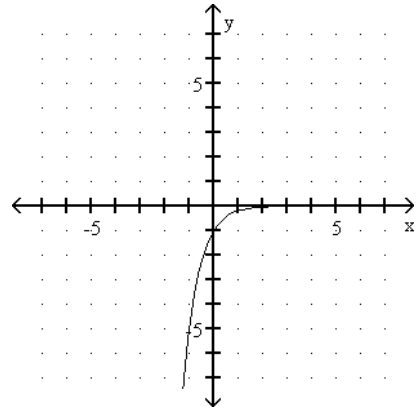

D)

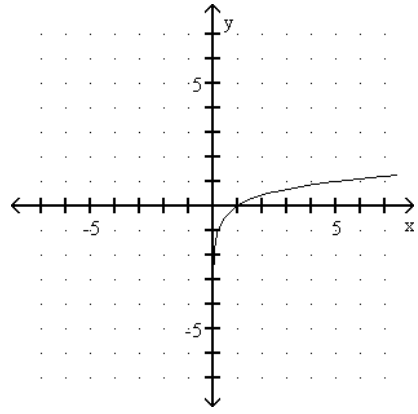

90) $y = \log_{1/5} x$

90) _____

A)

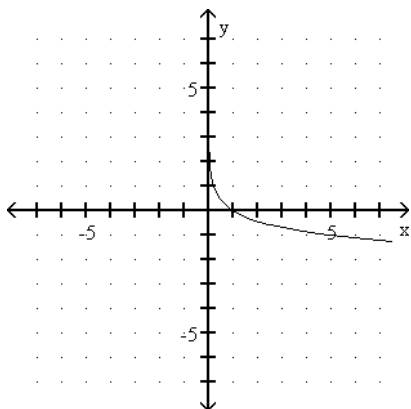

B)

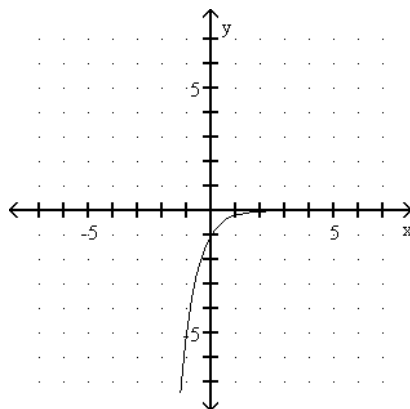

C)

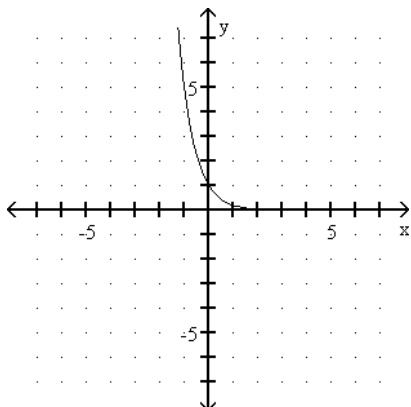

D)

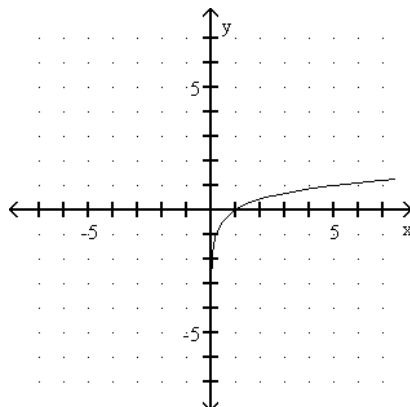

Use properties of logarithms to expand the logarithmic expression as much as possible.

91) $\log_a \frac{x^4 \sqrt[3]{x+5}}{(x-2)^2}$

91) _____

A) $4 \log_a x - 3 \log_a (x+5) - 2 \log_a (x-2)$

B) $\log_a x^4 + \log_a (x+5)^{-3} - \log_a (x-2)^2$

C) $4 \log_a x + \frac{1}{3} \log_a (x+5) - 2 \log_a (x-2)$

D) $\log_a x^4 + \log_a (x+5)^{1/3} - \log_a (x-2)^2$

Write as a logarithm of a single expression.

92) $3 \log_5 3 + \frac{1}{7} \log_5 (r-7) - \frac{1}{2} \log_5 r$

92) _____

A) $\log_5 \sqrt{\frac{3r-21}{14r}}$

B) $\log_5 \left(\frac{3}{14} \sqrt{\frac{r-7}{r}} \right)$

C) $\log_5 \frac{27r-7}{14r}$

D) $\log_5 \frac{27 \sqrt[7]{r-7}}{\sqrt{r}}$

Evaluate.

93) $7^{\log_7 5} + 8^{\log_8 4}$

A) $15 \log_{15} 9$

B) $56 \log_{56} 20$

C) 67

D) 9

93) _____

Find the common logarithm of the number. Round answer to four decimal places.

94) $\log 0.0649$

A) -1.1878

B) -1.1945

C) -1.1811

D) -2.7349

94) _____

Find the number N. Round N to six decimal places.

95) $\log N = -2.5554$

A) 0.002784

B) 359.252666

C) 0.555213

D) 12.876449

95) _____

Solve the equation without using a calculator.

96) $4^{(3x - 7)} = 16$

A) -3

B) $\frac{1}{4}$

C) 4

D) 3

96) _____

97) $3^{-x} = \frac{1}{9}$

A) $\frac{1}{3}$

B) -2

C) 2

D) $\frac{1}{2}$

97) _____

Solve the equation. Use a calculator where appropriate. If the answer is irrational, round to the nearest hundredth.

98) $\log_2 x = -3$

A) $\frac{1}{6}$

B) 8

C) $\frac{1}{8}$

D) -8

98) _____

99) $\log_{125} x = \frac{1}{3}$

A) $\frac{1}{5}$

B) 5

C) $\frac{1}{15}$

D) 15

99) _____

100) $\log_2 (-8 - 3x) = 2$

A) 4

B) $-\frac{1}{4}$

C) -4

D) $\frac{1}{4}$

100) _____

101) $\log_9 (5x - 3) = \log_9 (3x + 7)$

A) 5

B) 4

C) 2

D) no solution

101) _____

102) $\log (2 + x) - \log (x - 3) = \log 2$

A) 8

B) -8

C) $\frac{3}{2}$

D) no solution

102) _____

Find the value of N. Round to three decimal places.

103) $\ln N = -1.3$

A) 8.772

B) 0.114

C) 3.663

D) 0.273

103) _____

Use the change of base formula to find the value of the following logarithm. Do not round logarithms in the change of base formula. Write the answer rounded to the nearest ten-thousandth.

104) $\log_{24} 311$

A) 3.8730

B) 0.5537

C) 1.8061

D) 1.1125

104) _____

Solve the equation.

105) $\ln x + \ln(x - 1) = \ln 2$

A) $\frac{3}{2}$

B) 2

C) 2, -1

D) -1

105) _____